

# XSD

# EOM

Engineering  
Operation &  
Maintenance

## Surge Dampeners



Advance your process



# WILDEN®

A DOVER COMPANY

WIL-19011-E-03  
Replaces WIL-19011-E-02

**TABLE OF CONTENTS**

**SECTION 1 CAUTIONS—READ FIRST! .....1**

**SECTION 2 WILDEN PUMP DESIGNATION SYSTEM .....2**

**SECTION 3 HOW IT WORKS—PUMP & AIR DISTRIBUTION SYSTEM .....3**

**SECTION 4 DIMENSIONAL DRAWINGS .....4**

**SECTION 5 PERFORMANCE**

    XSD1 .....6

    XSD2 .....7

    XSD3 .....8

**SECTION 6 SUGGESTED INSTALLATION & TROUBLESHOOTING .....9**

**SECTION 7 ASSEMBLY / DISASSEMBLY ..... 11**

    Reassembly Hints & Tips..... 14

**SECTION 8 EXPLODED VIEW & PARTS LISTING**

    XSD1 Metal

        PTFE/Rubber/SIPD/Ultra-Flex™ -Fitted ..... 16

    XSD2 Metal

        PTFE/Rubber/SIPD/Ultra-Flex™ -Fitted ..... 18

    XSD2 Metal Advanced

        PTFE/Rubber/SIPD/Ultra-Flex™ -Fitted ..... 20















    XSD3 Metal

        PTFE/Rubber/Ultra-Flex™ -Fitted..... 22

**SECTION 9 ELASTOMER OPTIONS.....24**



## CAUTIONS—READ FIRST!

-  **CAUTION:** Do not over-lubricate air supply — excess lubrication will reduce performance.
-  **CAUTION:** Do not exceed 8.6 bar (125 psig) air supply pressure.
-  **CAUTION:** When choosing dampener materials, be sure to check the temperature limits for all wetted components. Example: Viton® has a maximum limit of 176.7°C (350°F) but polypropylene has a maximum limit of only 79°C (175°F).
-  **CAUTION:** Maximum temperature limits are based upon mechanical stress only. Certain chemicals will significantly reduce maximum safe operating temperatures. Consult Chemical Resistance Guide (E4) for chemical compatibility and temperature limits.
-  **TEMPERATURE LIMITS:**
- |                                |                    |                |
|--------------------------------|--------------------|----------------|
| Neoprene                       | -17.7°C to 93.3°C  | 0°F to 200°F   |
| Buna-N                         | -12.2°C to 82.2°C  | 10°F to 180°F  |
| EPDM                           | -51.1°C to 137.8°C | -60°F to 280°F |
| Viton®                         | -40°C to 176.7°C   | -40°F to 350°F |
| Saniflex™                      | -28.9°C to 104.4°C | -20°F to 220°F |
| Polytetrafluoroethylene (PTFE) | 4.4°C to 104.4°C   | 40°F to 220°F  |
| Polyurethane                   | -12.2°C to 65.6°C  | 10°F to 150°F  |
| SIPD PTFE w/EPDM Backed        | -10°C to 137°C     | 14°F to 280°F  |
- NOTE: Not all materials are available for all models. Refer to Section 2 for material options for your pump.
-  **WARNING:** Prevention of static sparking — If static sparking occurs, fire or explosion could result. Dampener, pump, valves, and containers must be grounded to a proper grounding point when handling flammable fluids and whenever discharge of static electricity is a hazard.
-  **CAUTION:** The process fluid and cleaning fluids must be chemically compatible with all wetted dampener components. Consult Chemical Resistance Guide (E4).
-  **CAUTION:** Dampener(s) should be thoroughly flushed before installing into process lines. FDA and USDA approved dampeners should be cleaned and/ or sanitized before being used.
-  **CAUTION:** Always wear safety glasses when operating dampener. If diaphragm rupture occurs, process fluid may be forced out air exhaust.
-  **CAUTION:** Before any maintenance or repair is attempted, the compressed air line to the dampener and pump should be disconnected and all air pressure allowed to bleed from the system. Disconnect all intake, discharge and air lines. Drain the dampener by allowing any fluid to flow into a suitable container.
-  **CAUTION:** Blow out air line for 10 to 20 seconds before attaching to dampener to make sure all pipeline debris is clear. Use an in-line air filter. A 5µ (micron) air filter is recommended.
-  **CAUTION:** Dampeners cannot be used in submersible applications.
-  **CAUTION:** Tighten all hardware prior to installation.
-  **CAUTION:** ATEX products have been assessed for use in potentially explosive atmospheres in accordance with the European Directive 94/9/EC (ATEX 95). Users of ATEX products must be familiar with ATEX requirements and follow all safety guidelines. (Refer to Wilden Safety Supplement WIL-18510-E).



**WILDEN DESIGNATION SYSTEM**

**XSD EQUALIZER®**

**LEGEND**

**XSD X/XXXX/XXX/XX/XXXX**



**MATERIAL CODES**

**MODEL**

XSD = ATEX EQUALIZER®  
SURGE DAMPENER

**INLET SIZE**

1 = 25mm (1")  
2 = 51mm (2")  
3 = 76mm (3")

**WETTED PATH/  
OUTER PISTON**

AA = ALUMINUM/ALUMINUM  
SS = STAINLESS STEEL/  
STAINLESS STEEL

**AIR CHAMBER**

A = ALUMINUM  
S = STAINLESS STEEL

**REGULATOR BODY**

A = ALUMINUM  
S = STAINLESS STEEL

**DIAPHRAGM**

BNS = BUNA-N (red dot)  
FSS = SANIFLEX™ (cream)  
EPS = NORDEL® (blue dot)  
NES = NEOPRENE (green dot)  
PUS = POLYURETHANE (clear)  
TNU = PTFE W/NEOPRENE  
TEU = PTFE W/EPDM  
VTS = VITON® (silver or  
white dot)  
WFS = WIL-FLEX™ (orange dot)  
XBS = CONDUCTIVE BUNA-N  
(two red dots)

**ULTRA-FLEX™ DIAPHRAGM**

BNU = BUNA-N (red dot)  
EPU = NORDEL® (blue dot)  
NEU = NEOPRENE (green dot)  
VTU = VITON® (silver or  
white dot)

**O-RINGS**

BN = BUNA-N  
TF = PTFE (White)<sup>1</sup>  
TV = PTFE Encapsulated Viton<sup>2</sup>

**NOTE:**

<sup>1</sup>XSD1 and XSD2 Only  
<sup>2</sup>XSD3 Only

**SPECIALTY CODES**

0014 BSPT  
0040 ASNI Flange Connection (Advanced™)

NOTE: MOST ELASTOMERIC MATERIALS USE COLORED DOTS FOR IDENTIFICATION.

Viton® is a registered trademark of DuPont Elastomers.  
Hytrel® is a registered trademark of DuPont Elastomers.  
Santoprene® is a registered trademark of Exxon Mobil Corporation

## HOW IT WORKS—DAMPENER

All reciprocating pumps generate discharge pressure fluctuation. The Equalizer® minimizes unwanted pressure fluctuation by providing a supplementary pumping action. This is accomplished by using a diaphragm as a separation membrane within the Equalizer® to trap a given volume of liquid on one side and pressurized air on the other.

When the fluid pressure falls in the system, the Equalizer® supplies additional pressure to the discharge line between pump strokes by displacing fluid via diaphragm movement. This movement provides the supplementary pumping action needed to reduce pressure variation and pulsation.

The Equalizer® automatically sets and maintains the correct air pressure matching the variations in liquid flow or discharge pressure generated by the pump. A shaft attached to the Equalizer® diaphragm triggers the addition or removal of the air within the non-wetted side of the Equalizer®. The Equalizer® automatically adjusts to any pressure and/or flow setting of the pump with no need for manual adjustment of the unit and/or system. The Equalizer® has proven to be the cost effective choice for protecting your liquid process system from unwanted pulsation or pressure fluctuation. Contact your local Wilden distributor for further information on the Equalizer® and other pumping solutions.

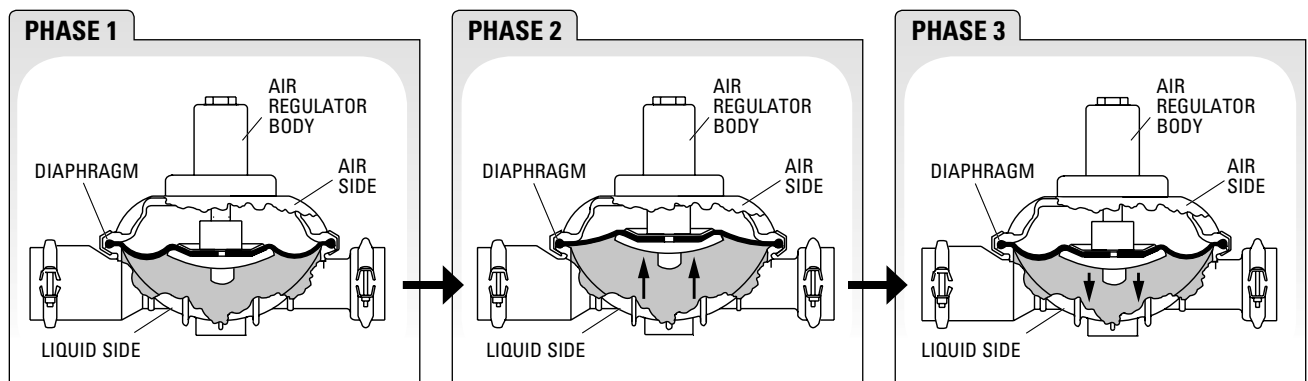

A compressed air line attached to the air regulator body sets and maintains pressure on the air side of the diaphragm. As the reciprocating pump begins its stroke, liquid discharge pressure increases which flexes the Equalizer® diaphragm inward. This action accumulates fluid in the liquid chamber (see phase 2) and the air regulator allows compressed air to enter the air side. When the pump redirects its motion

upon stroke completion, the liquid discharge pressure decreases and compressed air in the air side forces the Equalizer® diaphragm to flex outward displacing the fluid into the discharge line (see phase 3). This motion provides the supplementary pumping action needed to minimize pressure fluctuation.

**DIMENSIONAL DRAWINGS**

**XSD1**

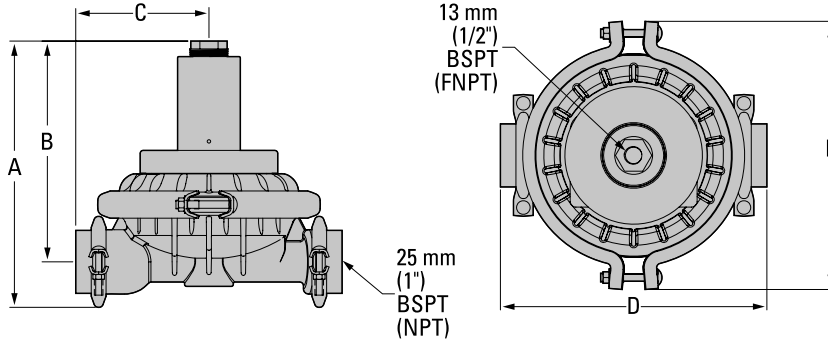

**DIMENSIONS — XSD1 METAL**

DIMENSION	METRIC (mm)	STANDARD (inch)
A	295	11.6
B	244	9.6
C	147	5.8
D	295	11.6
E	297	11.7

**XSD2**

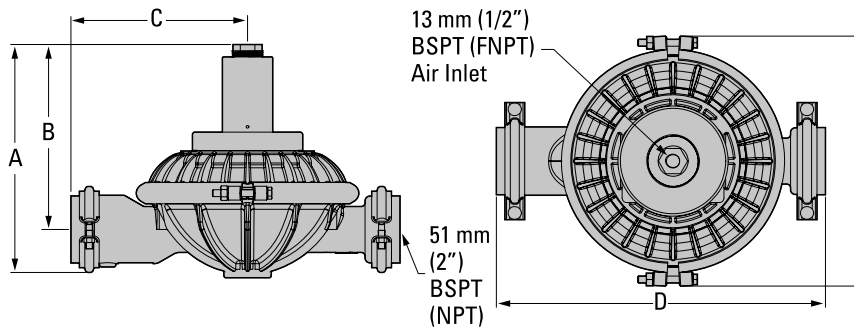

**DIMENSIONS — XSD2 METAL**

DIMENSION	METRIC (mm)	STANDARD (inch)
A	315	12.4
B	257	10.1
C	244	9.6
D	455	17.9
E	345	13.6

**DIMENSIONAL DRAWINGS**

**XSD2 Advanced™**

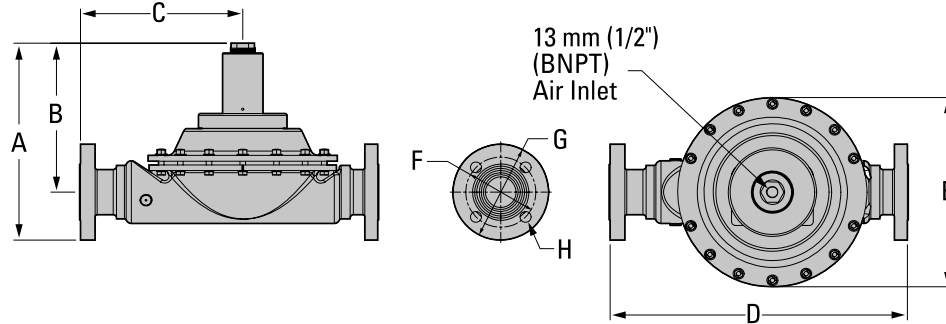

**DIMENSIONS -  
XSD2 ADVANCED METAL**

ITEM	METRIC (mm)	STANDARD (inch)
A	345	13.6
B	257	10.1
C	279	11.0
D	513	20.2
E	325	12.8
<b>DIN</b>		
F	125 DIA	4.9 DIA
G	165 DIA	6.5 DIA
H	18 DIA	.7 DIA
<b>ANSI</b>		
F	122 DIA	4.8 DIA
G	165 DIA	6.5 DIA
H	20 DIA	.8 DIA

**XSD3**

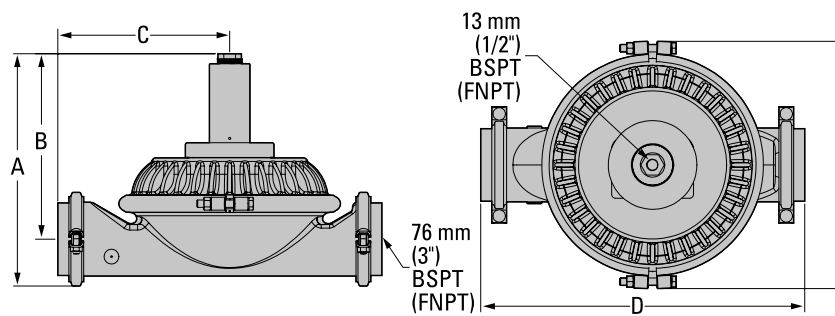

**DIMENSIONS — XSD3 METAL**

DIMENSION	METRIC (mm)	STANDARD (inch)
A	399	15.7
B	320	12.6
C	295	11.6
D	556	21.9
E	424	16.7



**XSD1 PERFORMANCE**

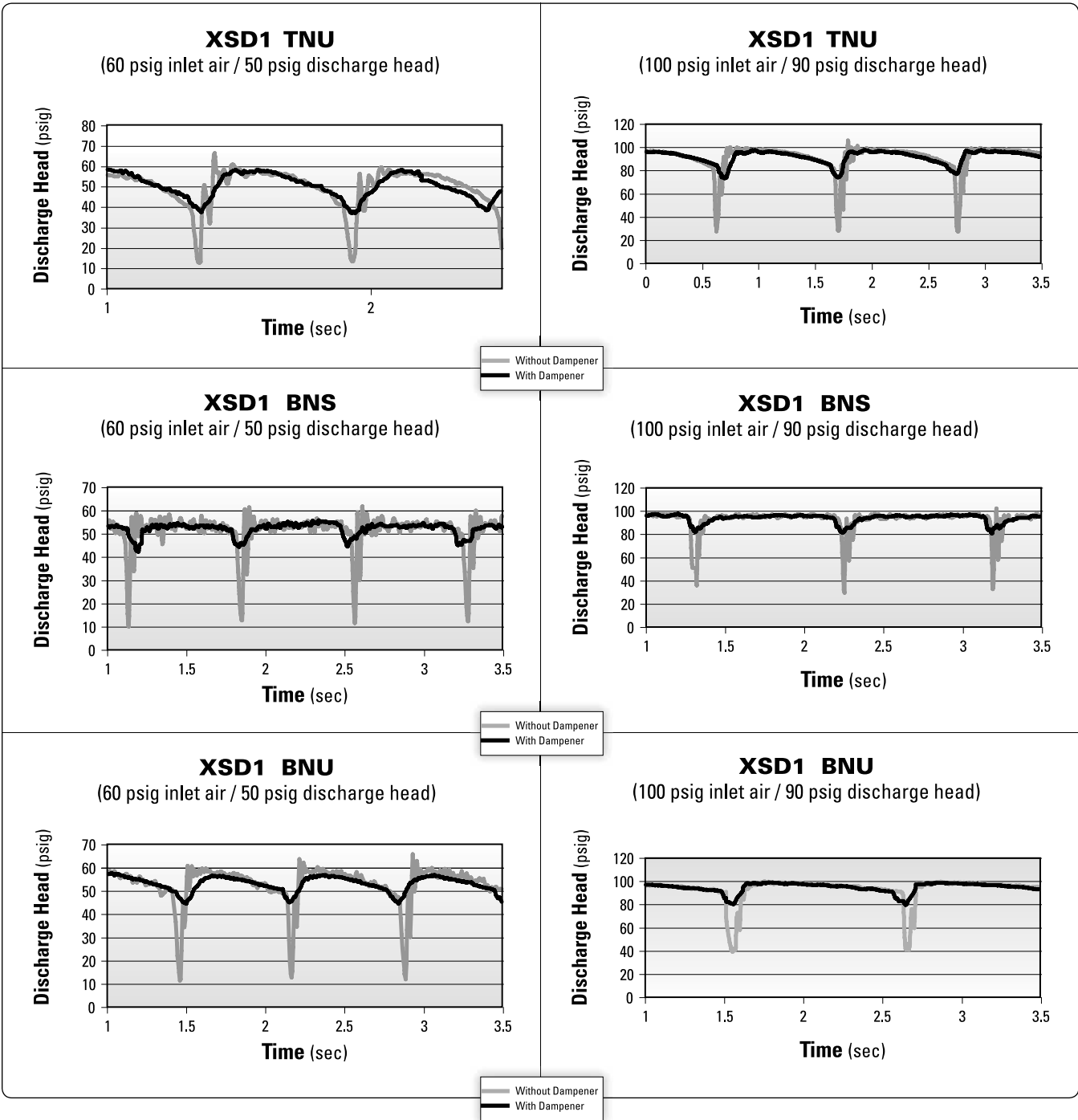

These charts show discharge head fluctuations for a diaphragm pump with and without a dampener. By reviewing the variation in pressure, the level of dampening can be estimated for an application. For example, the head pressure generated by a 1" pump operating at 100 psig air inlet pressure and 90 psig head pressure varies between 25

psig and 104 psig resulting in a total pressure fluctuation of 79 psig for each stroke. When an XSD1/AAAA/TNU/TF dampener is installed in the application, the head pressure varies between 69 psig and 96 psig resulting of a pressure fluctuation of only 27 psig. This results in a 67% reduction in head pressure fluctuation.



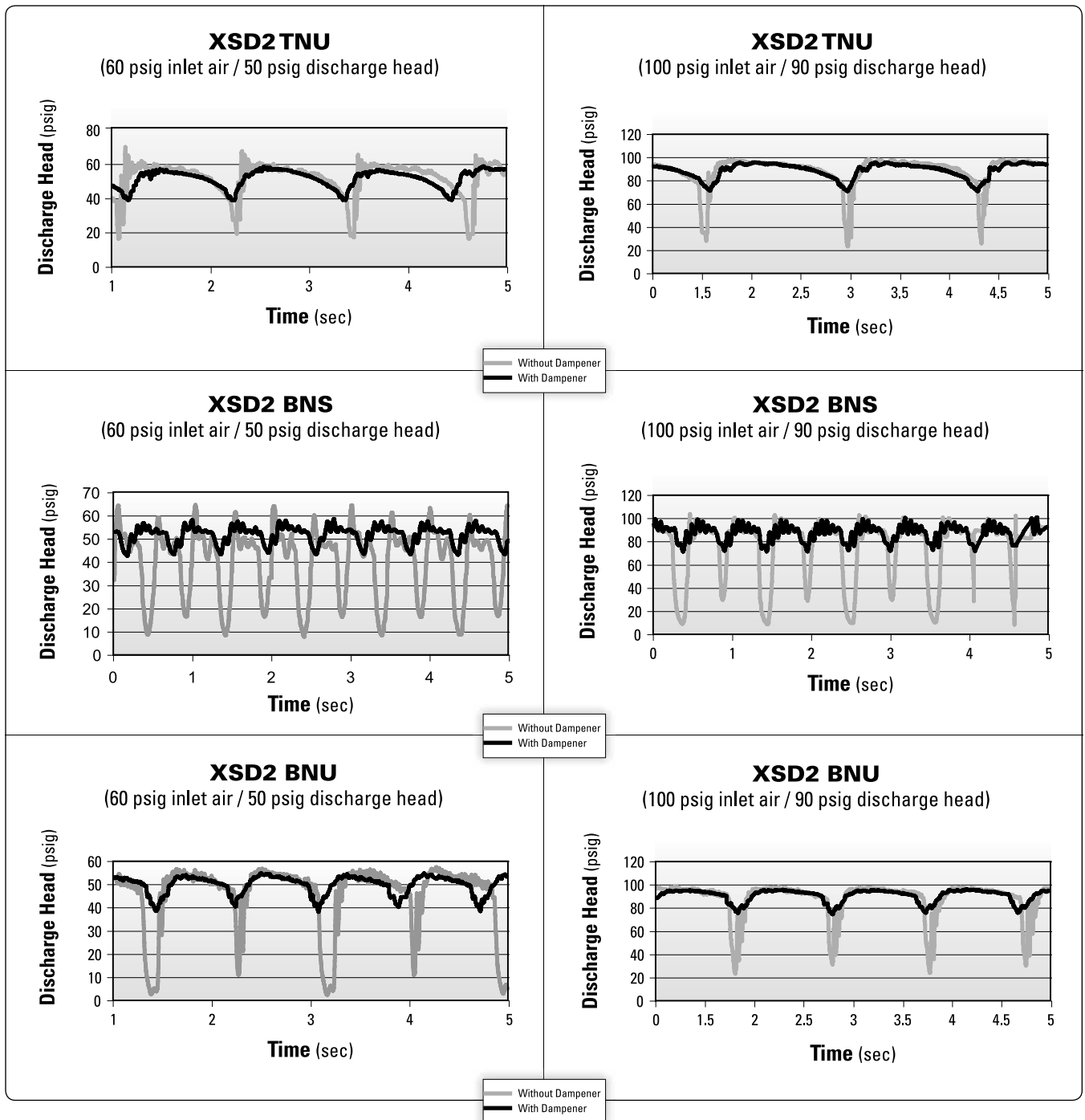

These charts show discharge head fluctuations for a diaphragm pump with and without a dampener. By reviewing the variation in pressure, the level of dampening can be estimated for an application. For example (XSD2 BNS 100/90), the head pressure generated by a 2" pump operating at 100 psig air inlet pressure and 90 psig head pressure varies between 6 psig and 102 psig resulting

in a total pressure fluctuation of 96 psig for each stroke. When an XSD2/AAAA/BNS/BN dampener is installed in the application, the head pressure varies between 68 psig and 99 psig resulting of a pressure fluctuation of only 31 psig. This results in a 68% reduction in head pressure fluctuation.

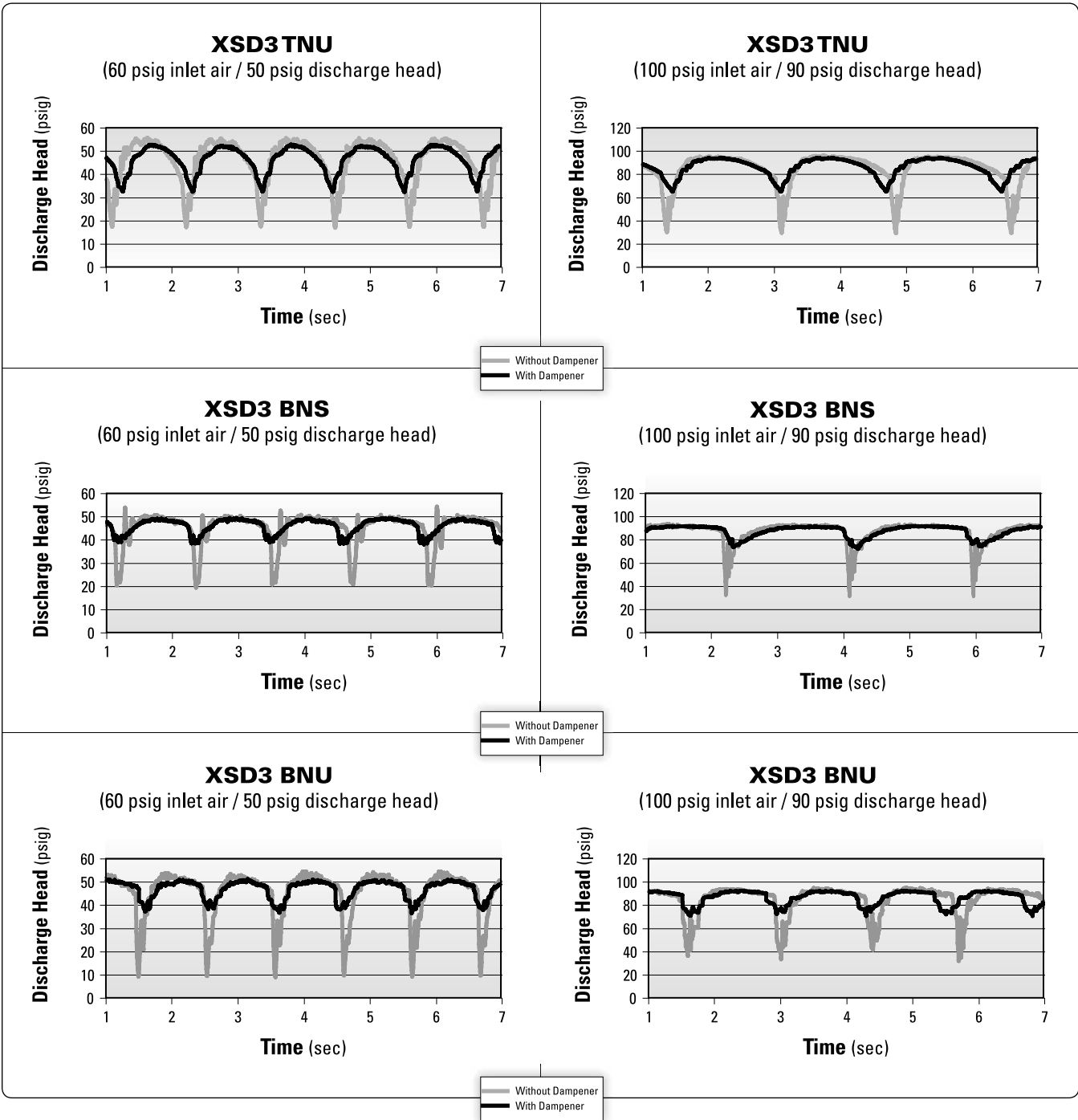

These charts show discharge head fluctuations for a diaphragm pump with and without a dampener. By reviewing the variation in pressure, the level of dampening can be estimated for an application. For example (XSD3 BNU 100/90), the head pressure generated by a 3" pump operating at 100 psig air inlet pressure and 90 psig head pressure varies between 30 psig and 94 psig resulting

in a total pressure fluctuation of 64 psig for each stroke. When an XSD3/AAAA/BNU/BN dampener is installed in the application, the head pressure varies between 69 psig and 91 psig resulting of a pressure fluctuation of only 22 psig. This results in a 66% reduction in head pressure fluctuation.

## SUGGESTED INSTALLATION

The model XSD1 has a 1" inlet/discharge. The model XSD2 has a 2" inlet/discharge and the XSD3 has a 3" inlet/discharge. The Equalizer® can be installed in either horizontal or vertical orientations. A variety of materials are available to satisfy temperature, chemical compatibility, abrasion and flex concerns.

The Equalizer® installed on the discharge side of the pump minimizes pulsation and protects in-line equipment. It can also be connected on the suction side to prevent water hammer associated with a positive inlet condition.

Install the Equalizer® as shown below. The use of flexible connections and a Filter, Regulator, Lubricator (FRL) will extend parts life. Shut off valves on the suction side of

pump and the discharge side of Equalizer® will enable maintenance personnel to safely service the equipment. To maximize effectiveness install the Equalizer® as close as possible to the discharge of the pump.

It is important to support the pipe immediately downstream from the Equalizer®. Use a tee connector on the pump air supply line and connect the line to the Equalizer® regulator body. This tee connector should be installed after the FRL. The Equalizer® consumes very little air, therefore, a 1/4" hose is more than adequate to supply enough air volume. When the air supply to the pump is shut down, the air to the Equalizer® will be shut off as well.

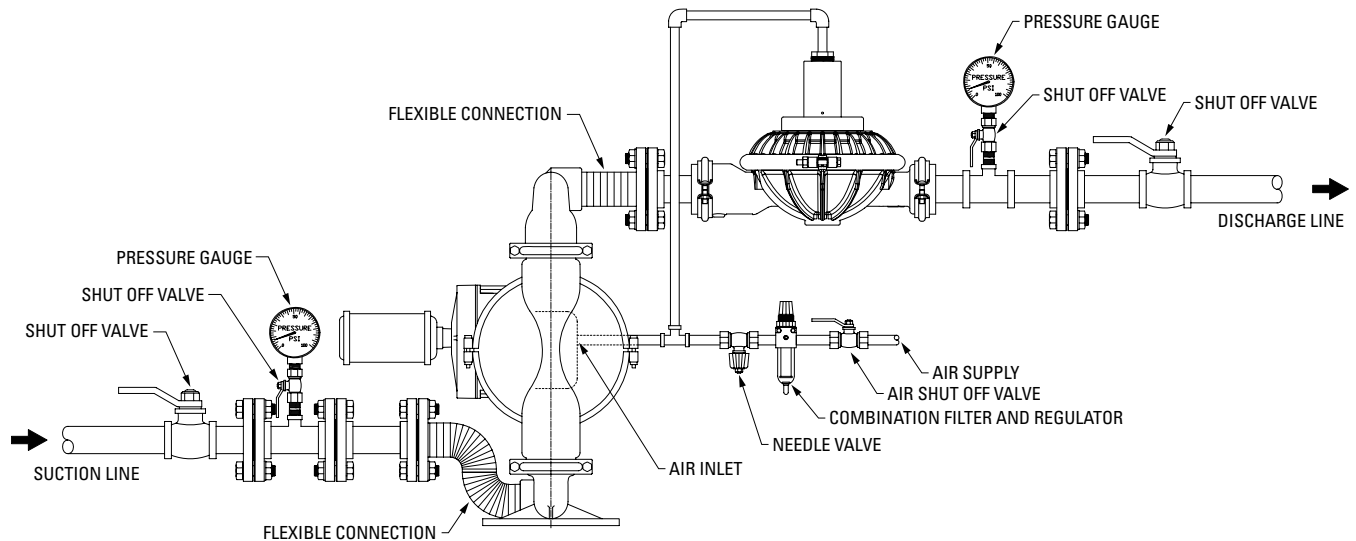

**NOTE:** In the event of a power failure, the shut off valve should be closed, if the restarting of the pump is not desirable once power is regained.

**AIR OPERATED PUMPS:** To stop the pump from operating in an emergency situation, simply close the

shut off valve (user supplied) installed in the air supply line. A properly functioning valve will stop the air supply to the pump, therefore stopping output. This shut off valve should be located far enough away from the pumping equipment such that it can be reached safely in an emergency situation.

## TROUBLESHOOTING

- 1) When there is a significant drop in the fluid discharge pressure, there will be a noticeable release of air through the small bleed hole in the air regulator body. This is how the Equalizer<sup>®</sup> automatically adjusts itself for optimal suppression. This is a good way of verifying proper operation of the unit. If there is a continuous discharge of air out this hole during steady fluid discharge pressure, the Equalizer<sup>®</sup> is not functioning properly and should be inspected. The air regulator body houses three (3) Glyd rings.
- 2) Fluid leakage around the clamp band area is normally stopped by tightening the clamp band bolts. If leakage continues, unit should be disassembled and inspected.
- 3) Air leakage between the adapter plate and air chamber requires tightening of four air chamber bolts on the inside of the air chamber.



## DAMPENER DISASSEMBLY

**Tools Required:**

- Deep well sockets and ratchet (7/16", 1/2", and 3/4")
- Hex(Allen<sup>®</sup>) wrenches (3/16" and 1/4")
- Large adjustable wrench or channel lock pliers

**Tools Recommended:**

- Large pipe wrench
- Vise equipped w/soft jaws (such as aluminum, plastic, plywood or other suitable material)

**CAUTION:** Before any maintenance or repair is attempted, the compressed air line to the Equalizer<sup>®</sup> and the pump should be disconnected and all air pressure allowed to bleed from the system. Disconnect all intake, discharge, and air lines. Be aware of any hazardous effects of contact with your process fluid. **PLEASE READ ALL DIRECTIONS BEFORE STARTING DISASSEMBLY.**

**NOTE:** The model photographed for these instructions is a XSD1 other Equalizer<sup>®</sup> models should be similar in design but may contain slightly different components and fastener sizes.

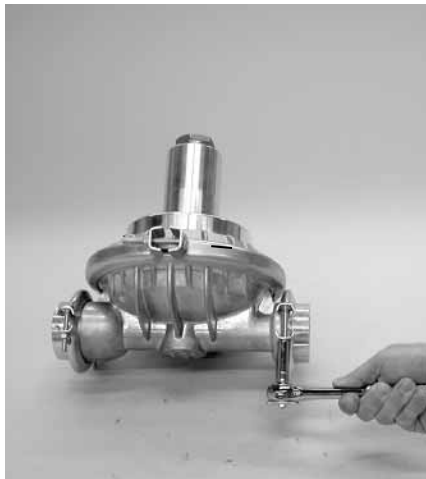
**Step 1**

Disassembly of the Surge ends/ small clamp band is needed only in the event of leakage. Leakage is usually stopped by tightening the small band bolts using a 7/16" deep well socket.

**Step 2**

If leakage persists, remove surge ends and replace O-rings.

**Step 3**

Remove large clamp band using a 1/2" deep well socket.



**Step 4**

Set liquid chamber aside.



**Step 5**

Remove reducer bushing at top of regulator.



**Step 6**

Loosen shaft assembly by using adjustable wrench on outer piston and 3/4" socket on shaft bolt inside air regulator body. Turn counter clockwise. One of two scenarios will occur: outer piston will loosen from shaft, or the shaft bolt will loosen from shaft.



**Step 7**

In either case, this will allow the removal of the inner and outer pistons, diaphragm, shaft stop, shaft, shaft stop washer and bolt.



**Step 8**

Inspect shaft for nicks or abrasion. Small nicks can usually be dressed out. If shaft is chemically attacked or nicks are hindering operation, shaft should be replaced.



**Step 9**

Disassembly of the air chamber from the regulator adaptor plate is needed only in the event of air leakage.

## DAMPENER DISASSEMBLY



### Step 10

In the event of an air leak, remove the air chamber and replace the gasket.



### Step 11

Disassembly of the regulator body from the regulator adaptor plate is needed only in the event of air leakage.



### Step 12

In the event of an air leak, remove the regulator adaptor plate and replace the O-ring.

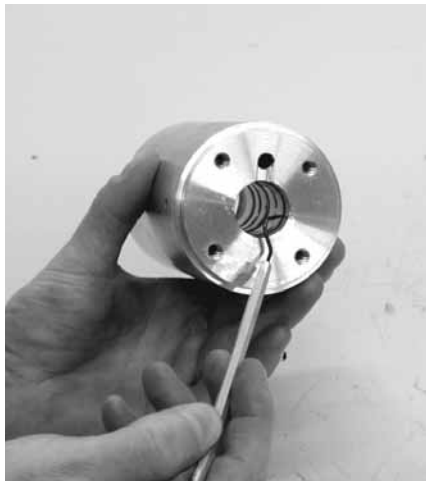

### Step 13

Using an O-ring pick remove the Glyd™-rings from air regulator body.

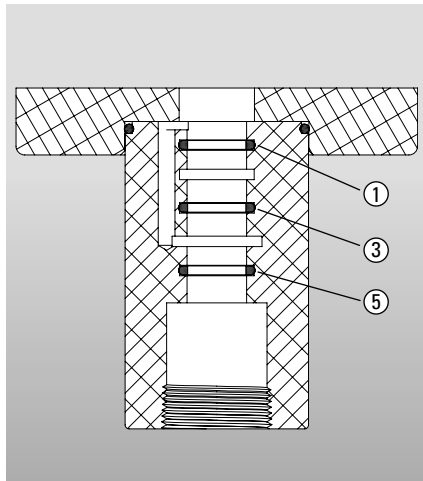

### Step 14

The air regulator body has 5 grooves cut into the inside diameter. There are three Glyd™-rings installed in the 1, 3, 5 positions. It is important that these Glyd™-rings be installed in the correct grooves so that the Equalizer® functions properly. Please refer to the drawing for the correct location of the Glyd™-rings.

## REASSEMBLY HINTS & TIPS

### ASSEMBLY:

Upon performing applicable maintenance to the air distribution system, the Equalizer® can now be reassembled. Please refer to the disassembly instructions for photos and parts placement. To reassemble the Equalizer®, follow the disassembly instructions in reverse order. The air regulator body needs to be assembled first, then the diaphragm and finally the wetted path. Please find the applicable torque specifications on this page. The following tips will assist in the assembly process.

- Lubricate air regulator body, Glyd rings and shaft bore center with NLGI grade 2 white EP bearing grease or equivalent.
- Clean the inside of the air regulator body bore to ensure no damage is done to new shaft seals.
- Stainless bolts should be lubed to reduce the possibility of seizing during tightening.

### MAXIMUM TORQUE SPECIFICATIONS

Model	Description of Part	Torque
<b>XSD1</b>	Air chamber/adaptor plate	24.4 N·m (18 ft-lbs)
	Air regulator body/adaptor plate	7.9 N·m (70 in-lbs)
	Outer piston/shaft bolt assembly (all diaphragms)	54.2 N·m (40 ft-lbs)
<b>XSD2</b>	Air chamber/adaptor plate	24.4 N·m (18 ft-lbs)
	Air chamber/adaptor plate	7.9 N·m (70 in-lbs)
	Outer piston/shaft bolt assembly (rubber & PTFE)	108.5 N·m (80 ft-lbs)
	Outer piston/shaft bolt assembly (Ultra-Flex™ & SIPD)	74.6 N·m (55 ft-lbs)
<b>XSD3</b>	Air chamber/adaptor plate	44.7 N·m (33 ft-lbs)
	Air regulator body/adaptor plate	7.9 N·m (70 in-lbs)
	Outer piston/shaft bolt assembly (all diaphragms)	135.6 N·m (100 ft-lbs)

### SHAFT SEAL INSTALLATION:

#### PRE-INSTALLATION

- Once all of the old seals have been removed, the inside of the air regulator body should be cleaned to ensure no debris is left that may cause premature damage to the new seals.

#### INSTALLATION

The following tools can be used to aid in the installation of the new seals:

Needle Nose Pliers  
Phillips Screwdriver  
Electrical Tape

- Wrap electrical tape around each leg of the needle nose pliers (heat shrink tubing may also be used). This is done to prevent damaging the inside surface of the new seal.
- With a new seal in hand, place the two legs of the needle nose pliers inside the seal ring. (See Figure A.)
- Open the pliers as wide as the seal diameter will allow, then with two fingers pull down on the top portion of the seal to form kidney bean shape. (See Figure B.)
- Lightly clamp the pliers together to hold the seal into the kidney shape. Be sure to pull the seal into as tight of a kidney shape as possible, this will allow the seal to travel down the bushing bore easier.
- With the seal clamped in the pliers, insert the seal into the bushing bore and position the bottom of the seal into the correct groove. Once the bottom of the seal is seated in the groove, release the clamp pressure on the pliers. This will allow the seal to partially snap back to its original shape.
- After the pliers are removed, you will notice a slight bump in the seal shape. Before the seal can be properly resized, the bump in the seal should be removed as much as possible. This can be done with either the Phillips screwdriver or your finger. With either the side of the screwdriver or your finger, apply light pressure to the peak of the bump. This pressure will cause the bump to be almost completely eliminated.
- Lubricate the edge of the shaft with NLGI grade 2 white EP bearing grease.
- Slowly insert the center shaft with a rotating motion. This will complete the resizing of the seal.
- Perform these steps for the remaining seal.

**Figure A**

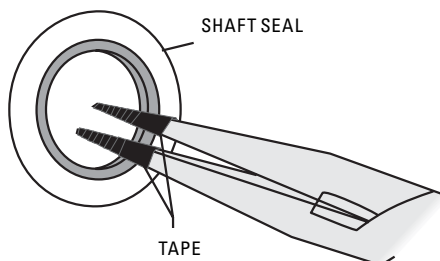

**Figure B**

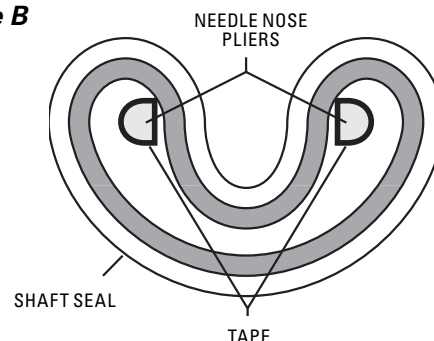



**NOTES**

**EXPLODED VIEW & PARTS LISTING**

**XSD1 ORIGINAL™ METAL**

**EXPLODED VIEW**

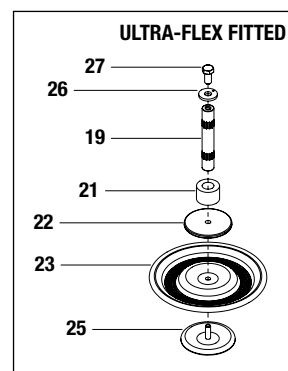
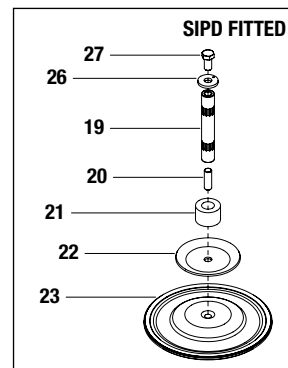
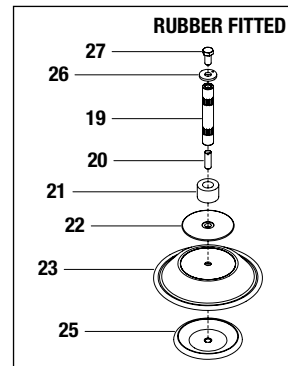
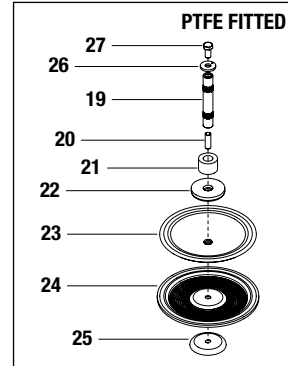
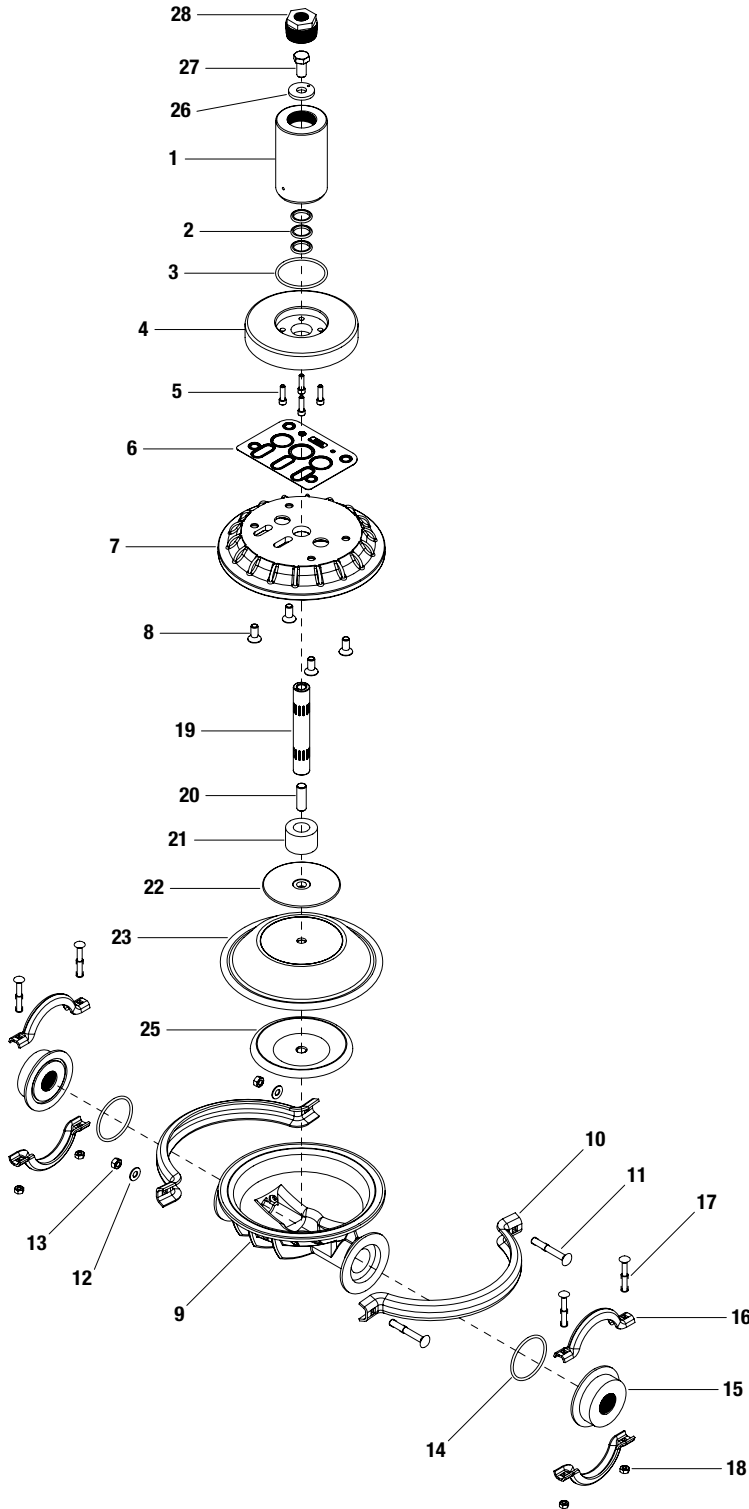

## EXPLODED VIEW & PARTS LISTING

### XSD1 ORIGINAL™ METAL

### PARTS LISTING

No.	Part Description	Model Description		XSD1/AAAA P/N	XSD1/SSSS P/N
			Qty.		
1	Body, Regulator <sup>1</sup>		1	76-8515-01	76-8515-03
2	<b>Ring II, Glyd</b>		3	<b>08-3210-55-225</b>	<b>08-3210-55-225</b>
3	<b>O-Ring -230 (Ø2.484 x Ø.139)</b>		1	<b>76-1285-52</b>	<b>76-1285-52</b>
4	Plate, Regulator Adapter		1	76-8510-01	76-8510-03
5	Screw, 1/4-20 x .75 Soc Hd Cap		4	76-6250-03	76-6250-03
6	Gasket, Center Block		1	04-3529-52	04-3529-52
7	Chamber, Air		1	04-3660-01	04-3660-03
8	Screw, 3/8-16 x 1.00 Soc Flt Csk Hd Cap		4	71-6250-08	71-6250-08
9	Chamber, Liquid		1	04-5000-01	04-5000-03
10	Clamp Band, Half		2	04-7330-03	04-7330-03
11	Bolt, 5/16-18 x 2.50 Rnd Hd Sq Neck		2	04-6070-03	04-6070-03
12	Washer, Plain		2	01-6732-03	01-6732-03
13	Nut, 5/16-18 Hex		2	04-6420-08	08-6400-03
14	<b>O-Ring -229 (Ø2.359 x Ø.139)</b>		2	*	*
15	End, 1" NPT Surge		2	70-8600-01	70-8600-03
	End, 1" BSPT Surge		2	70-8600-01-14	70-8600-03-14
16	Clamp Band Small		4	04-7100-08	04-7100-03
17	Bolt, 1/4-20 x 2.00 Rnd Hd Sq Neck		4	04-6050-08	01-6070-03
18	Nut, 1/4-20 Hex		4	04-6400-08	04-6400-03
19	Shaft, Straight		1	76-3800-03	76-3800-03
	Shaft, Ultra-Flex™		1	04-3830-03-07	04-3830-03-07
20	Stud, 1/2-20 x 1.50 Threaded		1	04-6150-08	04-6150-08
21	Stop, Shaft		1	76-8800-17	76-8800-17
22	Piston, Rubber & TPE Inner		1	04-3700-01-700	04-3700-01-700
	Piston, Ultra-Flex™ Inner		1	04-3760-01-700	04-3760-01-700
	Piston, PTFE Inner		1	04-3755-01	04-3755-01
	Piston, SIPD Inner		1	04-3700-08	04-3700-08
23	<b>Diaphragm, Primary</b>		1	*	*
	<b>Diaphragm, Ultra-Flex™</b>		1	*	*
	<b>Diaphragm, PTFE</b>		1	*	*
	<b>Diaphragm, SIPD</b>		1	*	*
24	<b>Diaphragm, Back-Up</b>		1	*	*
25	Piston, Rubber & TPE Outer		1	04-4552-01	04-4550-03
	Piston, Ultra-Flex™ Outer		1	04-4560-01	02-4550-03
	Piston, PTFE Outer		1	04-4600-01	04-4600-03
26	Washer, Stop		1	70-6790-08	70-6790-08
27	Screw, 1/2-20 x 1.00 Hex Cap		1	04-6090-08	04-6090-08
28	Reducer Bushing		1	70-6950-08	71-6950-03

<sup>1</sup>Air Regulator Body includes qty. 3 Glyd™ Rings.

\*Elastomer options listed on page 24.

**All Bold face items are primary wear items.**

**EXPLODED VIEW & PARTS LISTING**

**XSD2 ORIGINAL™ METAL**

**EXPLODED VIEW**

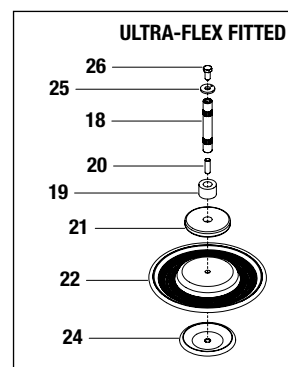
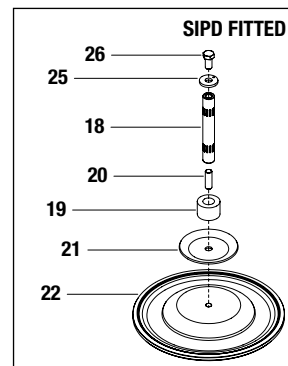
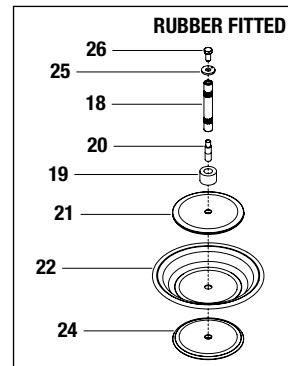
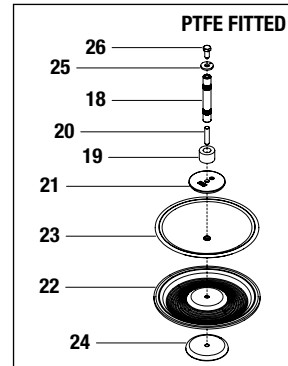
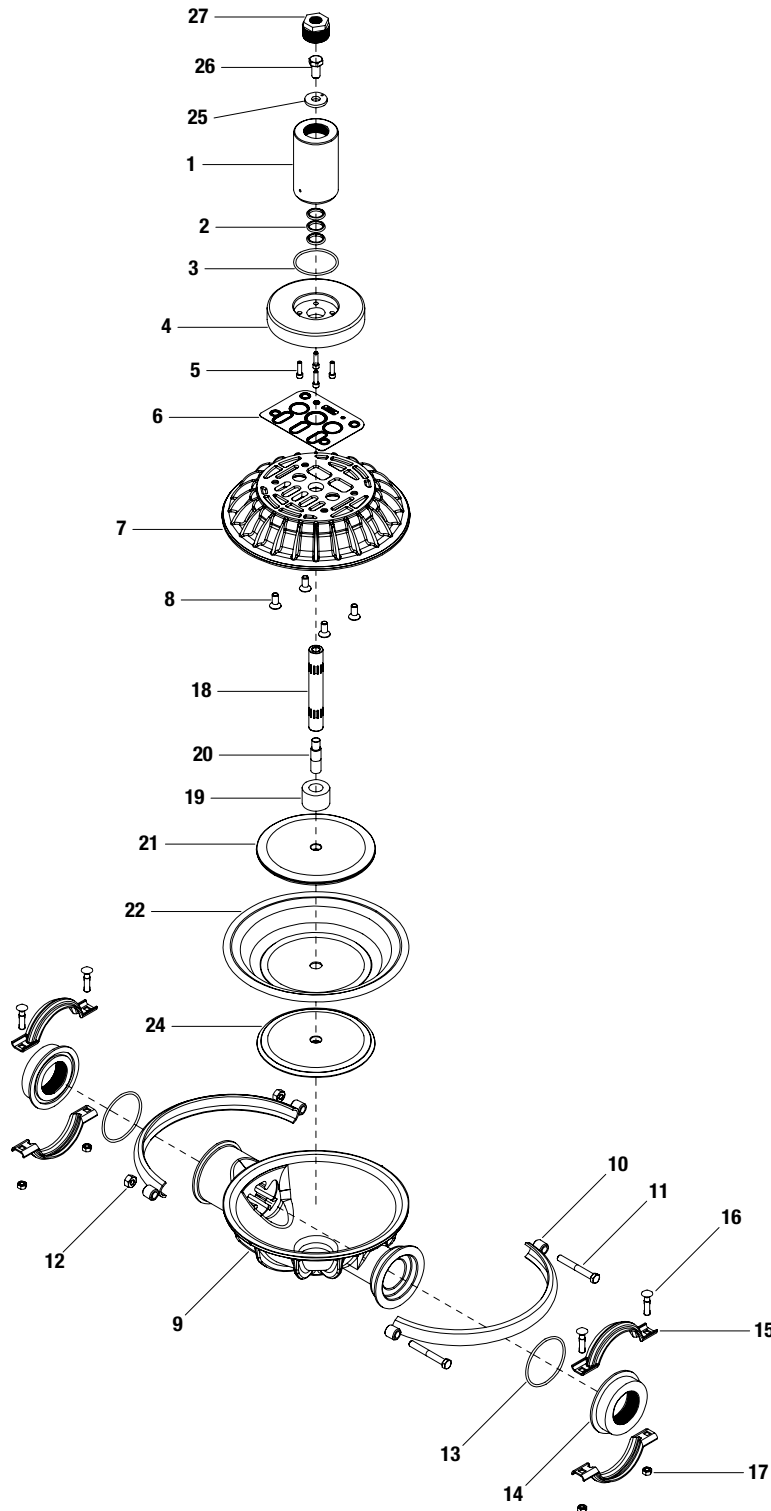

## EXPLODED VIEW & PARTS LISTING

### XSD2 ORIGINAL™ METAL

### PARTS LISTING

No.	Model Description		XSD2/AAAA P/N	XSD2/SSSS P/N
	Part Description	Qty.		
1	Body, Regulator <sup>1</sup>	1	76-8515-01	76-8515-03
2	<b>Ring II, Glyd</b>	<b>3</b>	<b>08-3210-55-225</b>	<b>08-3210-55-225</b>
3	<b>O-Ring -230 (Ø2.484 x Ø.139)</b>	<b>1</b>	<b>76-1285-52</b>	<b>76-1285-52</b>
4	Plate, Regulator Adapter	1	76-8510-01	76-8510-03
5	Screw, 1/4-20 x .75 Soc Hd Cap	4	76-6250-03	76-6250-03
6	Gasket, Center Block	1	04-3529-52	04-3529-52
7	Chamber, Air	1	08-3660-01	08-3660-03
8	Screw, 3/8-16 x 1.00 Soc Flt Csk Hd Cap	4	71-6250-08	71-6250-08
9	Chamber, Liquid	1	08-5000-01	08-5000-03
10	Clamp Band, Half	2	08-7300-08	08-7300-03
11	Screw, 3/8-16 x 3.00 Hex Cap	2	08-6120-08	08-6120-03
12	Nut, 3/8-16 Heavy Hex	2	08-6450-08	08-6450-03
13	<b>O-Ring -235 (Ø3.109 x Ø.139)</b>	<b>2</b>	<b>*</b>	<b>71-1280-55</b>
14	End, 2" NPT Surge	2	71-8601-01	71-8601-03
	End, 2" BSPT Surge	2	71-8601-01-14	71-8601-03-14
15	Band, Small Clamp	4	08-7100-08	08-7100-08
16	Bolt, 5/16-18 x 1.50 Rnd Hd Sq Neck	4	08-6050-08	08-6050-08
17	Nut, 5/16-18 Hex	4	04-6420-08	04-6420-03
18	Shaft, Straight	1	77-3800-03	77-3800-03
19	Stop, Shaft	1	71-8800-17	71-8800-17
20	Adapter, Shaft Stud Rubber Fitted	1	71-6153-08	71-6153-08
	Stud, 1/2- 20 x 1.88 Threaded Ultra-Flex	1	08-6150-08	08-6150-08
	Stud, 1/2- 20 x 2.13 Threaded PTFE		08-6152-08	08-6152-08
21	Piston, Rubber & TPE Inner	1	08-3700-01	08-3700-01
	Piston, Ultra-Flex™ Inner	1	08-3761-01	08-3761-01
	Piston, PTFE Inner	1	08-3750-01	08-3750-01
	Piston, SIPD Inner	1	04-3700-08	04-3700-08
22	<b>Diaphragm, Primary</b>	<b>1</b>	<b>*</b>	<b>*</b>
	<b>Diaphragm, Ultra-Flex™</b>	<b>1</b>	<b>*</b>	<b>*</b>
	<b>Diaphragm, PTFE</b>	<b>1</b>	<b>*</b>	<b>*</b>
	<b>Diaphragm, SIPD</b>	<b>1</b>	<b>*</b>	<b>*</b>
23	<b>Diaphragm, Backup</b>	<b>1</b>	<b>*</b>	<b>*</b>
24	Piston, Rubber & TPE Outer	1	08-4550-01	08-4550-03
	Piston, Ultra-Flex™ Outer	1	04-4552-01	04-4550-03
	Piston, PTFE Outer	1	08-4600-01	08-4600-03
25	Washer, Stop	1	70-6790-08	70-6790-08
26	Screw, 1/2-20 x 1.00 Hex Cap	1	04-6090-08	04-6090-08
27	Reducer Bushing	1	70-6950-08	70-6950-08

<sup>1</sup>Air Regulator Body includes qty. 3 Glyd™ Rings.

\*Elastomer options listed on page 24.

**All Bold face items are primary wear items.**

**EXPLODED VIEW & PARTS LISTING**

**XSD2 ADVANCED™ METAL**

**EXPLODED VIEW**

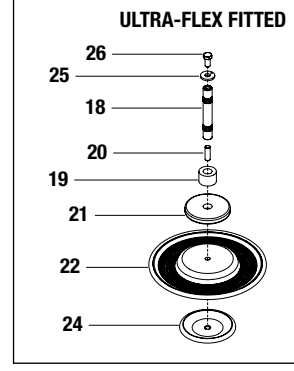
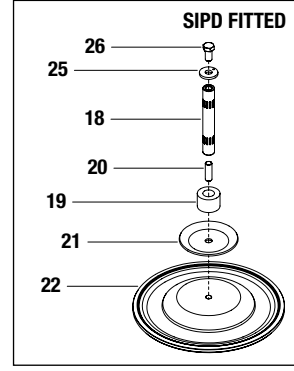
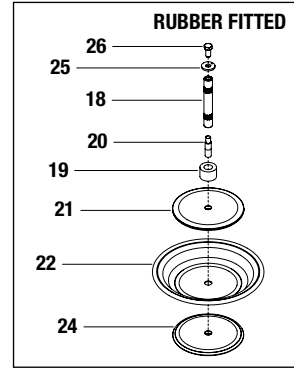
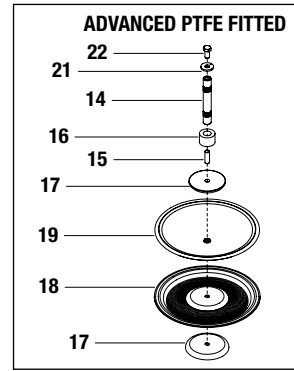
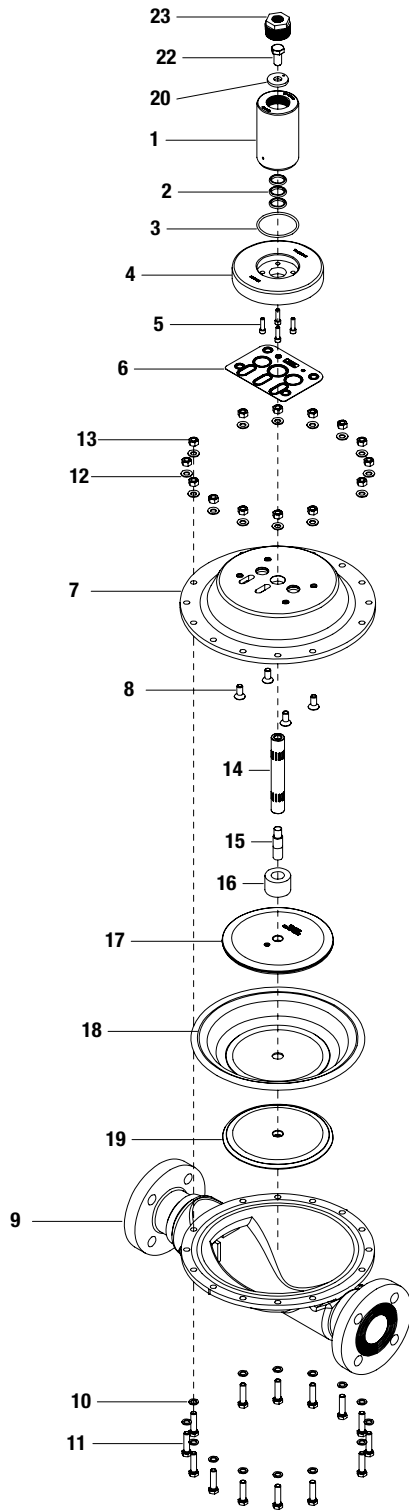

## EXPLODED VIEW & PARTS LISTING

### XSD2 ADVANCED™ METAL

### PARTS LISTING

Model Description			XSD2/AAAA/040
No.	Part Description	Qty.	P/N
1	Body, Regulator <sup>1</sup>	1	76-8515-01
<b>2</b>	<b>Ring II, Glyd</b>	<b>3</b>	<b>08-3210-55-225</b>
<b>3</b>	<b>O-Ring -230 (Ø2.484 x Ø.139)</b>	<b>1</b>	<b>76-1285-52</b>
4	Plate, Regulator Adapter	1	76-8510-01
5	Screw, 1/4-20 x .75 Soc Hd Cap	4	76-6250-03
6	Gasket, Center Block	1	04-3529-52
7	Chamber, Air	1	08-3690-01
8	Screw, 3/8-16 x 1.00 Soc Flt Csk Hd Cap	4	71-6250-08
9	Chamber, Liquid	1	71-5000-03-42
10	Washer (Type A), Plain	14	02-6730-03
11	Screw, 3/8-16 x 1.75 Hex Cap	14	04-6181-03
12	Spring (Belleville Type), Disk	14	08-6820-03-42
13	Nut, 3/8-16 Hex	14	02-6430-03
14	Shaft, Straight	1	77-3800-03
15	Adapter, Shaft Stud Rubber Fitted	1	71-6153-08
	Stud, 1/2-20 x 1.88 Threaded Ultra-Flex™	1	08-6150-08
	Stud, 1/2-20 x 2.13 Threaded PTFE	1	08-6152-08
16	Stop, Shaft	1	71-8800-17
17	Piston, Rubber & TPE Inner	1	08-3700-01
	Piston, Ultra-Flex™ Inner	1	08-3761-01
	Piston, PTFE Inner	1	08-3750-01
	Piston, SIPD Inner	1	04-3700-08
<b>18</b>	<b>Diaphragm, Primary</b>	<b>1</b>	<b>*</b>
	<b>Diaphragm Ultra-Flex™</b>	<b>1</b>	<b>*</b>
	<b>Diaphragm, PTFE</b>	<b>1</b>	<b>*</b>
	<b>Diaphragm, SIP</b>	<b>1</b>	<b>*</b>
<b>19</b>	<b>Diaphragm, Backup</b>	<b>1</b>	<b>*</b>
20	Piston, Rubber & TPE Outer	1	08-4550-03
	Piston, Ultra-Flex™ Outer	1	04-4550-03
	Piston, PTFE Outer	1	08-4600-03
21	Washer, Stop	1	70-6790-08
22	Screw, 1/2-20 x 1.00 Hex Cap	1	04-6090-08
23	Reducer Bushing	1	70-6950-08

<sup>1</sup>Air Regulator Body includes qty. 3 Glyd™ Rings.

\*Elastomer options listed on page 24.

**All Bold face items are primary wear items.**

**EXPLODED VIEW & PARTS LISTING**

**XSD3 ORIGINAL™ METAL**

**EXPLODED VIEW**

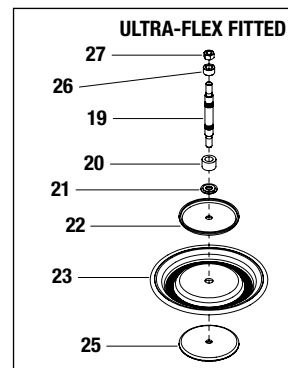
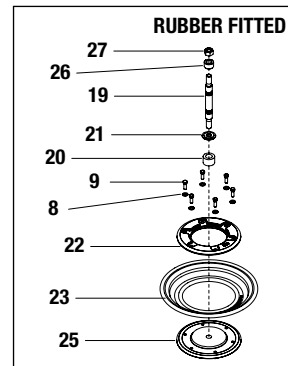
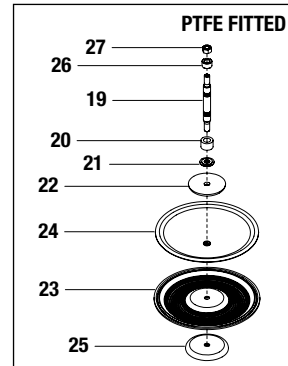
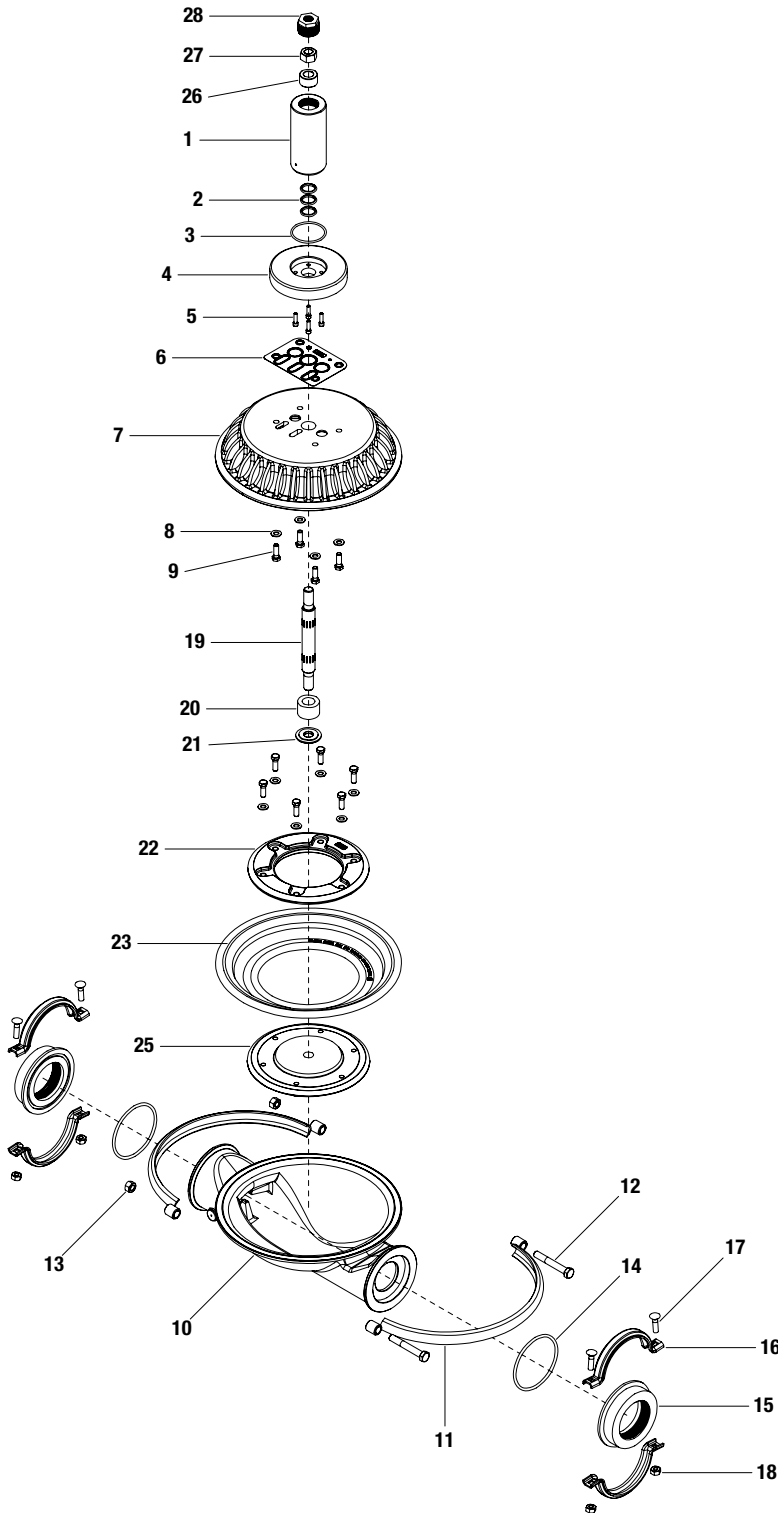



## EXPLODED VIEW & PARTS LISTING

### XSD3 ORIGINAL™ METAL

### PARTS LISTING

No.	Part Description	Model Description		XSD3/AAAA/ P/N	XSD3/SSSS/ P/N
			Qty.		
1	Body, Regulator <sup>1</sup>		1	78-8515-01	78-8515-03
2	<b>Ring II, Glyd</b>		3	<b>15-3210-55-225</b>	<b>15-3210-55-225</b>
3	<b>O-Ring -230 (Ø2.484 x Ø.139)</b>		1	<b>76-1285-52</b>	<b>76-1285-52</b>
4	Plate, Regulator Adapter		1	76-8510-01	76-8510-03
5	Screw, 1/4-20 x .75 Soc Hd Cap		4	76-6250-03	76-6250-03
6	Gasket, Center Block		1	04-3529-52	04-3529-52
7	Chamber, Air		1	15-3660-01	15-3660-03
8	Washer, Plain		10	15-6740-08-50	15-6740-08-50
9	Screw, 3/8-16 x 1.13 Hex Cap		10	15-6130-08	15-6130-08
10	Chamber, Liquid		1	15-5000-01	15-5000-03
11	Clamp Band, Half		2	15-7300-08	15-7300-03
12	Screw, 1/2-13 x 3.50 Hex Cap		2	15-6120-08	15-6120-03
13	Nut, 1/2-13 Heavy Hex		2	15-6420-08	15-6420-03
14	<b>O-Ring -348 (Ø4.350 x Ø.210)</b>		2	<b>08-1371-52</b>	<b>08-1371-52</b>
15	End, 3" NPT Surge		2	78-8600-01	78-8600-03
	End, 3" BSPT Surge		2	78-8600-01-14	78-8600-03-14
16	Band, Small Clamp		4	15-7100-08	15-7100-03
17	Bolt, 5/16-18 x 2.25 Rnd Hd Sq Neck		4	15-6050-08	15-6050-08
18	Nut, 3/8-16 Heavy Hex		4	08-6450-08	08-6450-03
19	Shaft, Straight		1	78-3800-03	78-3800-03
20	Stop, Shaft		1	78-8800-17	78-8800-17
21	Washer, Shoulder		1	15-6850-08	15-6850-08
22	Piston, Rubber & TPE Inner		1	15-3700-01	15-3700-01
	Piston, Ultra-Flex™ Inner		1	15-3760-08	15-3760-08
	Piston, PTFE Inner		1	15-3750-01	15-3750-01
23	<b>Diaphragm, Primary</b>		1	*	*
	<b>Diaphragm, Ultra-Flex™</b>		1	*	*
	<b>Diaphragm, PTFE</b>		1	*	*
24	<b>Diaphragm, Backup</b>		1	*	*
25	Piston, Rubber & TPE Outer		1	15-4550-01	15-4550-03
	Piston, Ultra-Flex™ Outer		1	15-4560-01	15-4560-03
	Piston, PTFE Outer		1	15-4600-03	15-4600-03
26	Stop, Washer		1	78-6790-08	78-6790-08
27	Nut, 3/4-16 Hex		1	78-6450-08	78-6450-08
28	Reducer Bushing		1	70-6950-08	70-6950-03

<sup>1</sup>Air Regulator Body includes qty. 3 Glyd™ Rings.

\*Elastomer options listed on page 24.

**All Bold face items are primary wear items.**



## ELASTOMER OPTIONS

	ELASTOMER	DIAPHRAGM	BACK-UP DIAPHRAGM	ULTRA-FLEX™ DIAPHRAGM	SIP DIAPHRAGM	O-RINGS
<b>XSD1 Original™ METAL EQUALIZER®</b>	NEOPRENE	04-1010-51	04-1060-51	04-1020-51	04-1030-72	N/A
	NITRILE	04-1010-52	04-1060-52	04-1020-52	N/A	70-1280-52
	VITON®	04-1010-53	N/A	04-1020-53	N/A	N/A
	NORDEL®	04-1010-54	04-1060-54	04-1020-54	N/A	N/A
	PTFE	04-1010-55	N/A	N/A	N/A	70-1280-55
	SANIFLEX™	04-1010-56	04-1060-56	N/A	N/A	N/A
	WIL-FLEX™	04-1010-58	N/A	N/A	N/A	N/A
	EXSD NITRILE	04-1010-86	04-1020-86	N/A	N/A	N/A
<b>XSD2 Original™ METAL EQUALIZER®</b>	NEOPRENE	08-1010-51	08-1060-51	08-1020-51	08-1030-72	N/A
	NITRILE	08-1010-52	08-1060-52	08-1020-52	N/A	71-1281-52
	VITON®	08-1010-53	N/A	08-1020-53	N/A	N/A
	NORDEL®	08-1010-54	08-1060-54	08-1020-54	N/A	N/A
	PTFE	08-1010-55	N/A	N/A	N/A	71-1281-55
	SANIFLEX™	08-1010-56	08-1060-56	N/A	N/A	N/A
	WIL-FLEX™	08-1010-58	N/A	N/A	N/A	N/A
	EXSD NITRILE	08-1010-86	08-1060-86	N/A	N/A	N/A
<b>XSD2 Advanced™ METAL EQUALIZER®</b>	NEOPRENE	08-1010-51	08-1060-51	08-1020-51	08-1030-72	N/A
	NITRILE	08-1010-52	08-1060-52	08-1020-52	N/A	N/A
	VITON®	08-1010-53	N/A	08-1020-53	N/A	N/A
	NORDEL®	08-1010-54	08-1060-54	08-1020-54	N/A	N/A
	PTFE	08-1010-55-42	N/A	N/A	N/A	N/A
	SANIFLEX™	08-1010-56	08-1060-56	N/A	N/A	N/A
	WIL-FLEX™	08-1010-58	N/A	N/A	N/A	N/A
	EXSD NITRILE	08-1010-86	08-1060-86	N/A	N/A	N/A
<b>XSD3 Original™ METAL EQUALIZER®</b>	NEOPRENE	15-1010-51	15-1060-51	15-1020-51	N/A	N/A
	NITRILE	15-1010-52	15-1060-52	15-1020-52	N/A	08-1371-52
	VITON®	15-1010-53	N/A	15-1020-53	N/A	08-1371-60
	NORDEL®	15-1010-54	15-1060-54	15-1020-54	N/A	N/A
	PTFE	15-1010-55	N/A	N/A	N/A	N/A
	SANIFLEX™	15-1010-56	15-1060-56	N/A	N/A	N/A
	WIL-FLEX™	15-1010-58	N/A	N/A	N/A	N/A

## WARRANTY

Each and every product manufactured by Wilden Pump and Engineering, LLC is built to meet the highest standards of quality. Every pump is functionally tested to insure integrity of operation.

Wilden Pump and Engineering, LLC warrants that pumps, accessories and parts manufactured or supplied by it to be free from defects in material and workmanship for a period of five (5) years from date of installation or six (6) years from date of manufacture, whichever comes first. Failure due to normal wear, misapplication, or abuse is, of course, excluded from this warranty.

Since the use of Wilden pumps and parts is beyond our control, we cannot guarantee the suitability of any pump or part for a particular application and Wilden Pump and Engineering, LLC shall not be liable for any consequential damage or expense arising from the use or misuse of its products on any application. Responsibility is limited solely to replacement or repair of defective Wilden pumps and parts.

All decisions as to the cause of failure are the sole determination of Wilden Pump and Engineering, LLC.

Prior approval must be obtained from Wilden for return of any items for warranty consideration and must be accompanied by the appropriate MSDS for the product(s) involved. A Return Goods Tag, obtained from an authorized Wilden distributor, must be included with the items which must be shipped freight prepaid.

The foregoing warranty is exclusive and in lieu of all other warranties expressed or implied (whether written or oral) including all implied warranties of merchantability and fitness for any particular purpose. No distributor or other person is authorized to assume any liability or obligation for Wilden Pump and Engineering, LLC other than expressly provided herein.

### PLEASE PRINT OR TYPE AND FAX TO WILDEN

PUMP INFORMATION			
Item # _____		Serial # _____	
Company Where Purchased _____			
YOUR INFORMATION			
Company Name _____			
Industry _____			
Name _____		Title _____	
Street Address _____			
City _____	State _____	Postal Code _____	Country _____
Telephone _____	Fax _____	E-mail _____	Web Address _____
Number of pumps in facility? _____		Number of Wilden pumps? _____	
Types of pumps in facility (check all that apply): <input type="checkbox"/> Diaphragm <input type="checkbox"/> Centrifugal <input type="checkbox"/> Gear <input type="checkbox"/> Submersible <input type="checkbox"/> Lobe			
<input type="checkbox"/> Other _____			
Media being pumped? _____			
How did you hear of Wilden Pump? <input type="checkbox"/> Trade Journal <input type="checkbox"/> Trade Show <input type="checkbox"/> Internet/E-mail <input type="checkbox"/> Distributor			
<input type="checkbox"/> Other _____			

**ONCE COMPLETE, FAX TO (909) 783-3440**

NOTE: WARRANTY VOID IF PAGE IS NOT FAXED TO WILDEN

WILDEN PUMP & ENGINEERING, LLC